



MLMS SERIES
VERY SMALL, LOW NOISE SYNTHESIZERS
.25 - 32 GHz (In Bands)

FEATURES

- Superior Phase Noise
- 1 kHz Step Size
- External or Internal Reference
- Fits in a Single Slot PXI
- 5 Line Serial & USB Control
- Single, +5VDC Power Supply Option

APPLICATIONS

- Test Equipment
- Local Oscillators
- Frequency Converters

DESCRIPTION

The **MLMS-Series** of YIG-Based wideband synthesizers are ideal as the main local oscillators in receiving systems, frequency converters and test and measurement equipment. They provide 1 kHz frequency resolution over the 250 MHz to 32 GHz frequency range. Power levels of +8 to +13 dBm are provided through out the series and full band tuning speed is 1-3 mSec. The units are 2.5" x 2.5" x .65" high and fit a 1 Slot PXI chassis.

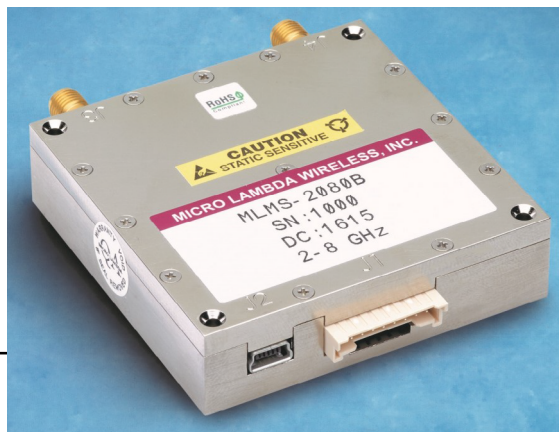

PERFORMANCE SPECIFICATIONS

(Operating Case Temperature: 0° to +60° C Baseplate) (Note 1)

Model No.	MLMS-0260	MLMS-2080	MLMS-4010	MLMS-6013	MLMS-8020	MLMS-2832
-----------	-----------	-----------	-----------	-----------	-----------	-----------

RF Specifications

Output Frequency (Note 2)	0.25-6 GHz	2-8 GHz	4-10 GHz	6-13 GHz	8-20 GHz	28-32 GHz
Output Power Min.	+11 dBm	+13 dBm	+10 dBm	+10 dBm	+8 dBm	+10 dBm
Po Variation over Freq/Temp	5 dB	4 dB	4 dB	6 dB	6 dB	5 dB
Step Size, Min.	1 kHz	1 kHz	1 kHz	1 kHz	1 kHz	1 kHz
Switching Speed, 100 MHz Step (Note 6)	1 mS	1 mS	1 mS	1 mS	1 mS	1 mS
1000 MHz Step	2 mS	2 mS	2 mS	2 mS	2 mS	2 mS
Full Band Step	3 mS	3 mS	3 mS	3 mS	3 mS	3 mS
Warm-up Time ("Lock") mSec	250	250	250	250	250	250
Output Impedance	50 Ohms	50 Ohms	50 Ohms	50 Ohms	50 Ohms	50 Ohms
Load VSWR	2.0:1	2.0:1	2.0:1	2.0:1	2.0:1	2.0:1
Harmonics & Subharmonics	-8 dBc	-12 dBc	-17 dBc	-17 dBc	-15 dBc	-20 dBc
Non-Harmonic Spurious	-60 dBc	-60 dBc	-60 dBc	-60 dBc	-54 dBc	-54 dBc

Phase Noise Performance

(with Internal Crystal Reference)

@ 100 Hz Offset	75 dBc/Hz	78 dBc/Hz	76 dBc/Hz	70 dBc/Hz	68 dBc/Hz	63 dBc/Hz
@ 1 kHz Offset	94 dBc/Hz	93 dBc/Hz	91 dBc/Hz	88 dBc/Hz	85 dBc/Hz	83 dBc/Hz
@ 10 kHz Offset	96 dBc/Hz	95 dBc/Hz	91 dBc/Hz	90 dBc/Hz	86 dBc/Hz	83 dBc/Hz
@ 100 kHz Offset	119 dBc/Hz	117 dBc/Hz	117 dBc/Hz	116 dBc/Hz	113 dBc/Hz	113 dBc/Hz
@ 1 MHz Offset	142 dBc/Hz	142 dBc/Hz	144 dBc/Hz	142 dBc/Hz	138 dBc/Hz	137 dBc/Hz
@ 10 MHz Offset	150 dBc/Hz	156 dBc/Hz	161 dBc/Hz	156 dBc/Hz	152 dBc/Hz	145 dBc/Hz
@ 100 MHz Offset	170 dBc/Hz	170 dBc/Hz	168 dBc/Hz	168 dBc/Hz	157 dBc/Hz	155 dBc/Hz

MLMS PERFORMANCE SPECIFICATIONS (Continued)

Model No.	MLMS-0260	MLMS-2080	MLMS-4010	MLMS-6013	MLMS-8020	MLMS-2832
Reference Oscillator Options						
Option A						
External Reference (Note 3)	50 - 200 MHz	50 - 200 MHz	50 - 200 MHz	50 - 200 MHz	50 - 200 MHz	50 - 200 MHz
External Ref. Input Power	0 +/- 3 dBm	0 +/- 3 dBm	0 +/- 3 dBm	0 +/- 3 dBm	0 +/- 3 dBm	0 +/- 3 dBm
Frequency Stability (<+/- 20ppm)	Cust Supplied	Cust Supplied	Cust Supplied	Cust Supplied	Cust Supplied	Cust Supplied
Option B						
External Reference with Internal Crystal (Note 4)	10 - 200 MHz	10 - 200 MHz	10 - 200 MHz	10 - 200 MHz	10 - 200 MHz	10 - 200 MHz
External Ref. Input Power	0 +/- 3 dBm	0 +/- 3 dBm	0 +/- 3 dBm	0 +/- 3 dBm	0 +/- 3 dBm	0 +/- 3 dBm
Frequency Stability (<+/- 10ppm)	Cust Supplied	Cust Supplied	Cust Supplied	Cust Supplied	Cust Supplied	Cust Supplied
Option C						
Internal Reference	100.0 MHz	100.0 MHz	100.0 MHz	100.0 MHz	100.0 MHz	100.0 MHz
Internal Frequency Accuracy (Note7)	2.5ppm	2.5ppm	2.5ppm	2.5ppm	2.5ppm	2.5ppm
Frequency Stability (0 to 60 °C)	1.0ppm	1.0ppm	1.0ppm	1.0ppm	1.0ppm	1.0ppm
Yearly Aging	1.5ppm	1.5ppm	1.5ppm	1.5ppm	1.5ppm	1.5ppm
Supply Voltage & Current						
+15 Vdc (± 0.5) Vdc (Note 5)	350 mA	450 mA	450 mA	500 mA	450 mA	300 mA
+5 Vdc (± 0.25) Vdc)	550 mA	450 mA	550 mA	550 mA	550 mA	650 mA
Total Power dissipation(Nom)	8.0 Watts	9.0 Watts	10.25 Watts	11.0 Watts	9.5 Watts	7.65 Watts
Supply Voltage Ripple (Pk-Pk from 60 Hz to 3 MHz)	<100 mV	<100 mV	<100 mV	<100 mV	<100 mV	<100 mV
Supply Voltage Option						
Option P (Note 8)						
+5 Vdc (± 0.5) Vdc)	1810 mA	2100 mA	2250 mA	2500 mA	2175 mA	1750 mA
Total Power dissipation(Nom)	9.05 Watts	10.5 Watts	11.25 Watts	12.5 Watts	10.9 Watts	8.75 Watts
Control Format (3.3V CMOS)	5-Line Serial USB	5-Line Serial USB	5-Line Serial USB	5-Line Serial USB	5-Line Serial USB	5-Line Serial USB
Phase Lock Alarm (J1-8) 3.3 V CMOS Logic	1=Locked	1=Locked	1=Locked	1=Locked	1=Locked	1=Locked
Weight	4.0 oz / 113 g	4.0 oz / 113 g	4.0 oz / 113 g	4.0 oz / 113 g	4.0 oz / 113 g	4.0 oz / 113 g
Outline Option A & B	211-001	211-001	211-001	211-001	211-001	211-001
Outline Option C	211-003	211-003	211-003	211-003	211-003	211-003
Outline Option P / A & B	211-004	211-004	211-004	211-004	211-004	211-004
Outline Option P / C	211-005	211-005	211-005	211-005	211-005	211-005

MLMS PERFORMANCE SPECIFICATIONS (Continued)

MLMS Options:

Option A: External Reference / No Internal Reference

Option B: External Reference / Internal Reference

Option C: Internal Reference Oscillator

Option P: Single, +5VDC Power Supply

Part Number Example: MLMS-2080A 2 GHz to 8 GHz with External Reference.

Notes:

- 1) Extended operating temperature range available.
- 2) Customer specified frequency ranges available.
- 3) 50-100 MHz OCXO recommended for best phase noise performance. External reference directly effects phase noise performance.
- 4) Output phase noise performance is not dependent on external reference phase noise.
- 5) +15Vdc required for wideband units (>4 GHz tuning range). +12Vdc available for ≤ 4 GHz tuning range.
- 6) For frequency settings <500 MHz, switching speed = 2.0 mS.
- 7) Improved accuracy is available upon request.
- 8) Current draw @ +5.0VDC +/-0.5V, =2100mA +13% @ 4.5V, -13% @ 5.5V

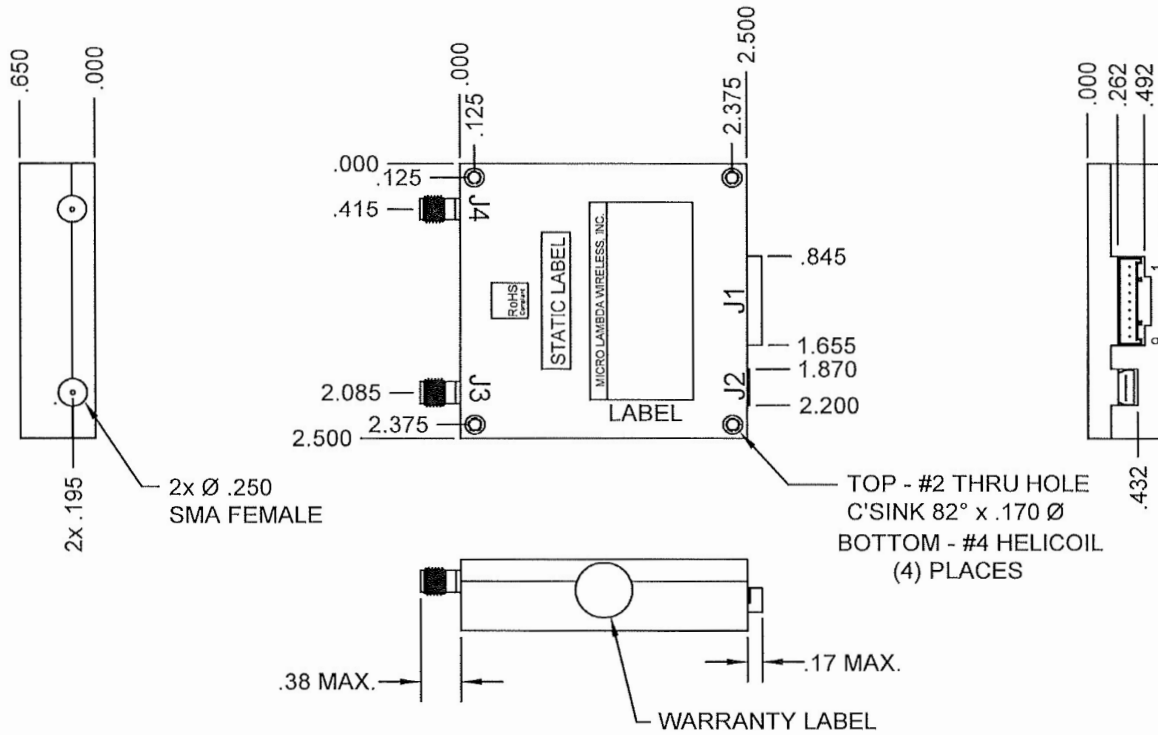

CONNECTIONS			
CONN.	TYPE	PIN #	FUNCTION
J1	35363-0960	1	+15 VDC, +12V OPT.
J1	35363-0960	2	GROUND (PWR/LOGIC)
J1	35363-0960	3	+ 5 VDC
J1	35363-0960	4	SERIAL CLOCK
J1	35363-0960	5	SERIAL DATA IN
J1	35363-0960	6	SERIAL SELECT/ENABLE
J1	35363-0960	7	SERIAL BUSY
J1	35363-0960	8	LOCK ALARM OUT
J1	35363-0960	9	SERIAL DATA OUT

CONNECTIONS			
CONN.	TYPE	PIN #	FUNCTION
J2	USB MINI-B	1	+V
J2	USB MINI-B	2	D-
J2	USB MINI-B	3	D+
J2	USB MINI-B	4	GND
J2	USB MINI-B	5	GND
J3	SMA-FEMALE	1	REF. INPUT OR NC
J4	SMA-FEMALE	1	RF OUTPUT

NOTES:

- J1 MALE: MOLEX# 0353630960
- J1 MATES WITH: MOLEX# 0355070900
- CRIMP PIN: MOLEX#0502128100
- J1 POWER SUPPLY INPUTS ARE REQUIRED FOR USB AND SPI OPERATION.
- J1 RECOMMENDED POWER SUPPLY WIRE SIZE = A.W.G. 22-24
- SMA ENGAGE/DISENGAGE TORQUE: 2 INCH-POUNDS MAX.
- SMA MATING TORQUE (ROTATIONAL): 8 INCH POUNDS MAX.
- SMA CONTACT RETENTION: 6 LBS. MIN. AXIAL FORCE ON MATING END. 4 IN-OZ MIN. RADIAL TORQUE.
- (*) ACTIVE LOW

UNLESS OTHERWISE SPECIFIED DIMENSIONS ARE IN INCHES TOLERANCE ARE: FRACTIONS DECIMALS ANGLES ▲ .xx ▲ 02 ▲ .xxx ▲ 010	CONTRACT NO.			MICRO LAMBDA WIRELESS, INC.	
	APPROVALS	DATE		MLMS SYNTHESIZER, EXT. REF.	
WEIGHT 4.0 Oz. / 113.4gr	DRAWN N.NGUYEN	DATE 3/25/2021	SIZE	CAGE No ORN63	DWG. NO. 99 - 0211 - 001
FINISH NICKEL	ENGR. DS	3/25/21	MANUF.	Q A	REV. C
DO NOT SCALE DRAWING					

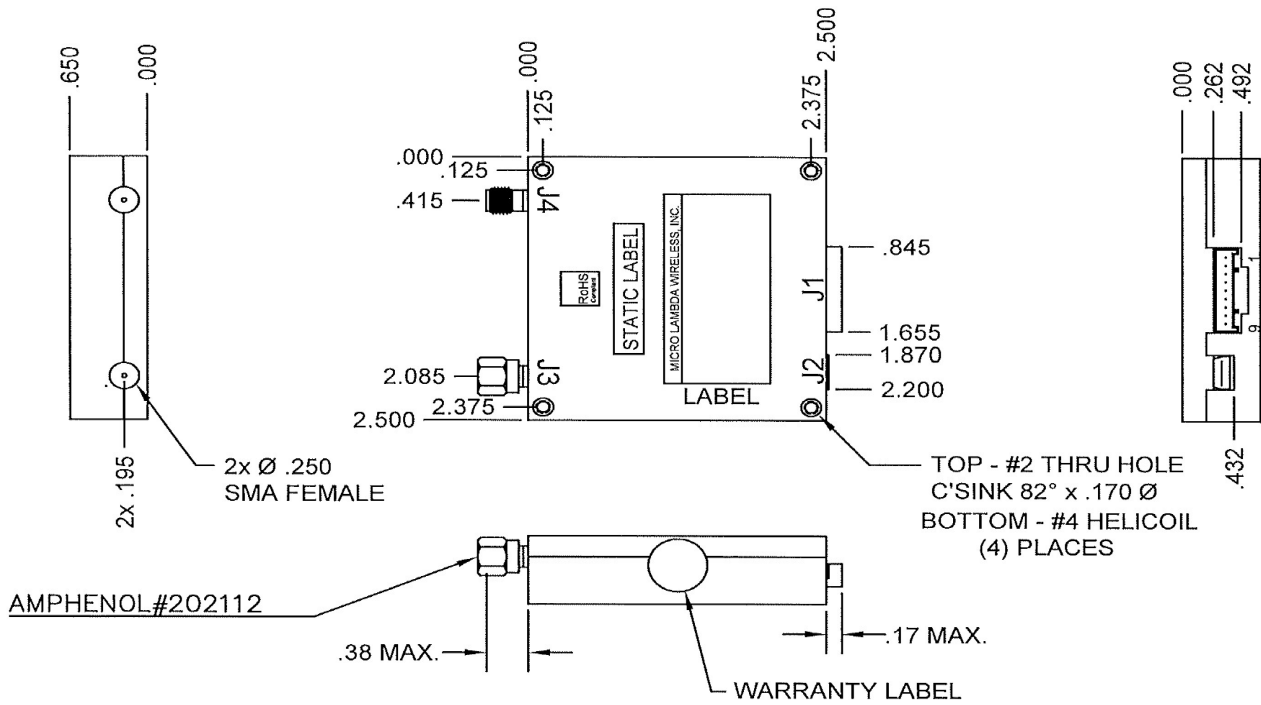

CONNECTIONS			
CONN.	TYPE	PIN #	FUNCTION
J1	35363-0960	1	+15 VDC, +12V OPT.
J1	35363-0960	2	GROUND (PWR/LOGIC)
J1	35363-0960	3	+ 5 VDC
J1	35363-0960	4	SERIAL CLOCK
J1	35363-0960	5	SERIAL DATA IN
J1	35363-0960	6	SERIAL SELECT/ENABLE
J1	35363-0960	7	SERIAL BUSY
J1	35363-0960	8	LOCK ALARM OUT
J1	35363-0960	9	SERIAL DATA OUT

CONNECTIONS			
CONN.	TYPE	PIN #	FUNCTION
J2	USB MINI-B	1	+V
J2	USB MINI-B	2	D-
J2	USB MINI-B	3	D+
J2	USB MINI-B	4	GND
J2	USB MINI-B	5	GND
J3	SMA-FEMALE	1	REF. INPUT OR NC
J4	SMA-FEMALE	1	RF OUTPUT

NOTES:

- J1 MALE: MOLEX# 0353630960
- J1 MATES WITH: MOLEX# 0355070900
- CRIMP PIN: MOLEX#0502128100
- J1 POWER SUPPLY INPUTS ARE REQUIRED FOR USB AND SPI OPERATION.
- J1 RECOMMENDED POWER SUPPLY WIRE SIZE = A.W.G. 22-24
- SMA ENGAGE/DISENGAGE TORQUE: 2 INCH-POUNDS MAX.
- SMA MATING TORQUE (ROTATIONAL): 8 INCH POUNDS MAX.
- SMA CONTACT RETENTION: 6 LBS. MIN. AXIAL FORCE ON MATING END. 4 IN-OZ MIN. RADIAL TORQUE.
- (*) ACTIVE LOW

UNLESS OTHERWISE SPECIFIED DIMENSIONS ARE IN INCHES TOLERANCE ARE: FRACTIONS: XX/100 DECIMALS: .XX ANGLES: Δ	CONTRACT NO.		<p>MICRO LAMBDA WIRELESS, INC.</p>				
	APPROVALS	DATE					
WEIGHT 4.0 Oz. / 113.4gr	DRAWN N. NGUYEN	6/16/2021	<p>MLMS SYNTHESIZER, INTERNAL REF.</p>				
FINISH NICKEL	ENGR. DS	6/16/21					
DO NOT SCALE DRAWING	MANUF.	Q.A.	<table border="1"> <tr> <td>SIZE</td> <td>CAGE No ORN63</td> <td>DWG. NO. 99 - 0211 - 003</td> <td>REV. A</td> </tr> </table>	SIZE	CAGE No ORN63	DWG. NO. 99 - 0211 - 003	REV. A
SIZE	CAGE No ORN63	DWG. NO. 99 - 0211 - 003	REV. A				

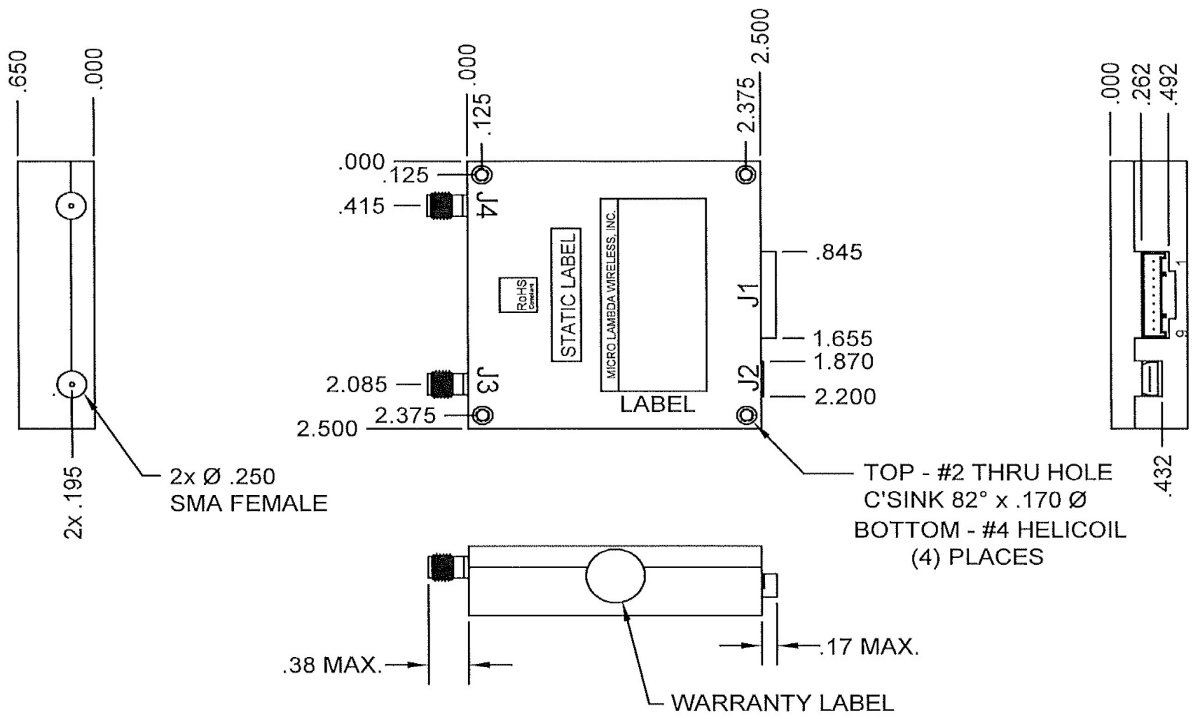

CONNECTIONS			
CONN.	TYPE	PIN #	FUNCTION
J1	35363-0960	1	N/A
J1	35363-0960	2	GROUND (PWR/LOGIC)
J1	35363-0960	3	+ 5 VDC
J1	35363-0960	4	SERIAL CLOCK
J1	35363-0960	5	SERIAL DATA IN
J1	35363-0960	6	SERIAL SELECT/ENABLE
J1	35363-0960	7	SERIAL BUSY
J1	35363-0960	8	LOCK ALARM OUT
J1	35363-0960	9	SERIAL DATA OUT

CONNECTIONS			
CONN.	TYPE	PIN #	FUNCTION
J2	USB MINI-B	1	+V
J2	USB MINI-B	2	D-
J2	USB MINI-B	3	D+
J2	USB MINI-B	4	GND
J2	USB MINI-B	5	GND
J3	SMA-FEMALE	1	REF. INPUT OR NC
J4	SMA-FEMALE	1	RF OUTPUT

NOTES:

- J1 MALE: MOLEX# 0353630960
- J1 MATES WITH: MOLEX# 0355070900
- CRIMP PIN: MOLEX#0502128100
- J1 POWER SUPPLY INPUTS ARE REQUIRED FOR USB AND SPI OPERATION.
- J1 RECOMMENDED POWER SUPPLY WIRE SIZE = A.W.G. 22-24
- SMA ENGAGE/DISENGAGE TORQUE: 2 INCH-POUNDS MAX.
- SMA MATING TORQUE (ROTATIONAL): 8 INCH POUNDS MAX.
- SMA CONTACT RETENTION: 6 LBS. MIN. AXIAL FORCE ON MATING END. 4 IN-OZ MIN. RADIAL TORQUE.
- (*) ACTIVE LOW

UNLESS OTHERWISE SPECIFIED DIMENSIONS ARE IN INCHES. TOLERANCE ARE: FRACTIONS DECIMALS ANGLES ± .010 ± .005 ± .010	CONTRACT NO.		<p>MICRO LAMBDA WIRELESS, INC.</p> <p>MLMS SYNTHESIZER, +5V SUPPLY, EXT. REF.</p>
	APPROVALS	DATE	
WEIGHT 4.0 Oz. / 113.4gr	DRAWN N.NGUYEN	5/25/2022	<p>SIZE CAGE No DWG. NO. REV.</p> <p>ORN63 99 - 0211 - 004 A</p>
FINISH NICKEL	ENGR. JS	5/25/22	
DO NOT SCALE DRAWING	MANUF.	Q.A.	

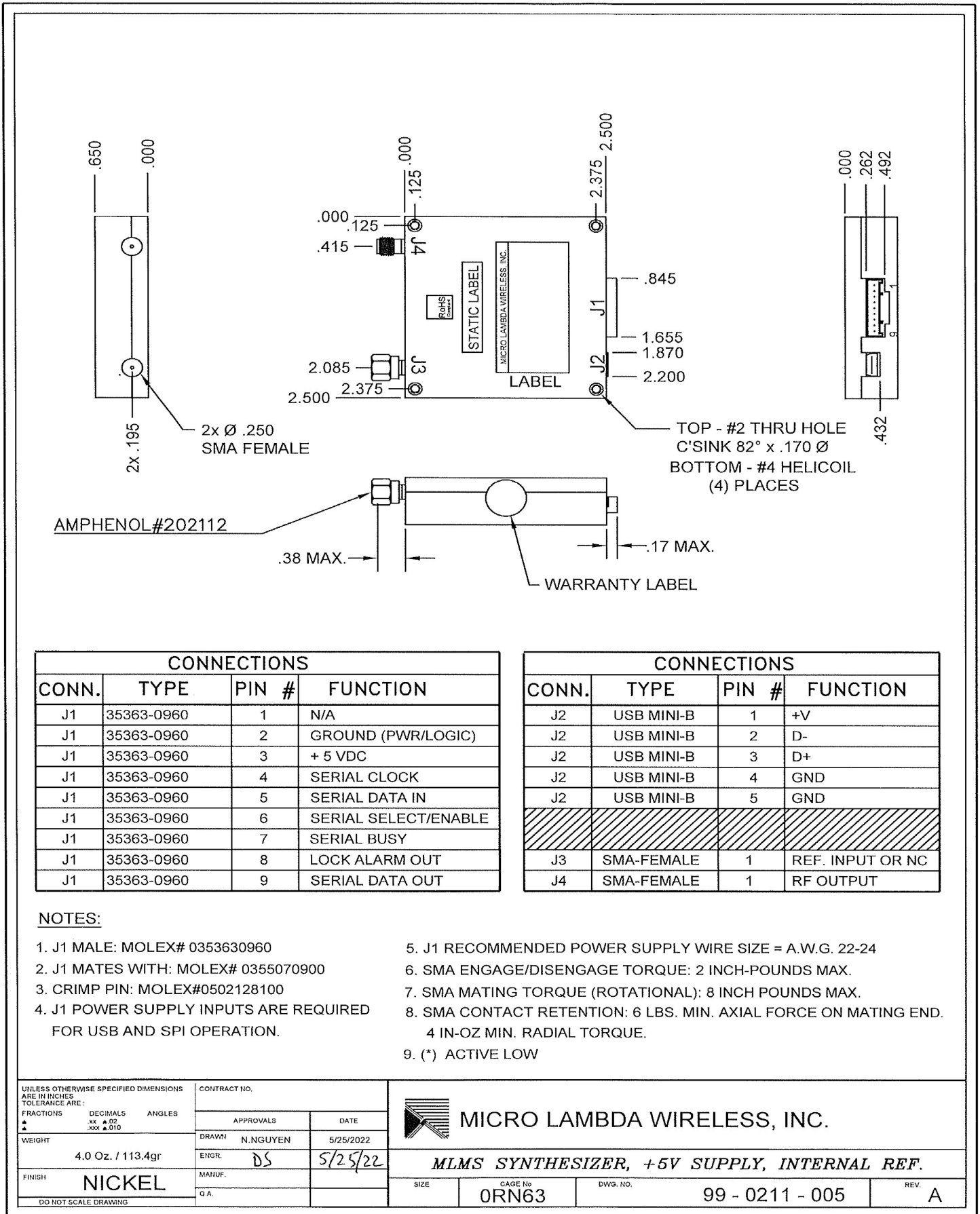

CONNECTIONS			
CONN.	TYPE	PIN #	FUNCTION
J1	35363-0960	1	N/A
J1	35363-0960	2	GROUND (PWR/LOGIC)
J1	35363-0960	3	+ 5 VDC
J1	35363-0960	4	SERIAL CLOCK
J1	35363-0960	5	SERIAL DATA IN
J1	35363-0960	6	SERIAL SELECT/ENABLE
J1	35363-0960	7	SERIAL BUSY
J1	35363-0960	8	LOCK ALARM OUT
J1	35363-0960	9	SERIAL DATA OUT

CONNECTIONS			
CONN.	TYPE	PIN #	FUNCTION
J2	USB MINI-B	1	+V
J2	USB MINI-B	2	D-
J2	USB MINI-B	3	D+
J2	USB MINI-B	4	GND
J2	USB MINI-B	5	GND
J3	SMA-FEMALE	1	REF. INPUT OR NC
J4	SMA-FEMALE	1	RF OUTPUT

NOTES:

- J1 MALE: MOLEX# 0353630960
- J1 MATES WITH: MOLEX# 0355070900
- CRIMP PIN: MOLEX#0502128100
- J1 POWER SUPPLY INPUTS ARE REQUIRED FOR USB AND SPI OPERATION.
- J1 RECOMMENDED POWER SUPPLY WIRE SIZE = A.W.G. 22-24
- SMA ENGAGE/DISENGAGE TORQUE: 2 INCH-POUNDS MAX.
- SMA MATING TORQUE (ROTATIONAL): 8 INCH POUNDS MAX.
- SMA CONTACT RETENTION: 6 LBS. MIN. AXIAL FORCE ON MATING END. 4 IN-OZ MIN. RADIAL TORQUE.
- (*) ACTIVE LOW

UNLESS OTHERWISE SPECIFIED DIMENSIONS ARE IN INCHES TOLERANCE ARE: FRACTIONS DECIMALS ANGLES ▲ xx ▲ .02 xxx ▲ .010	CONTRACT NO.			MICRO LAMBDA WIRELESS, INC.		
	APPROVALS	DATE				
WEIGHT 4.0 Oz. / 113.4gr	DRAWN N. NGUYEN	5/25/2022	MLMS SYNTHESIZER, +5V SUPPLY, INTERNAL REF.			
FINISH NICKEL	ENGR. DS	5/25/22				
DO NOT SCALE DRAWING	MANUF.	Q.A.	SIZE	CAGE No ORN63	DWG. NO. 99 - 0211 - 005	REV A